

THIS DRAWING IS UNPUBLISHED. RELEASED FOR PUBLICATION ,19 .  
 © COPYRIGHT 19 BY AMP INCORPORATED. ALL RIGHTS RESERVED.

LOC	DIST	REVISIONS					
		P	LTR	DESCRIPTION	DATE	DWN	APVD
G	14		J	REDRAWN PER 0720-0377-94	10OCT94	LO	ME

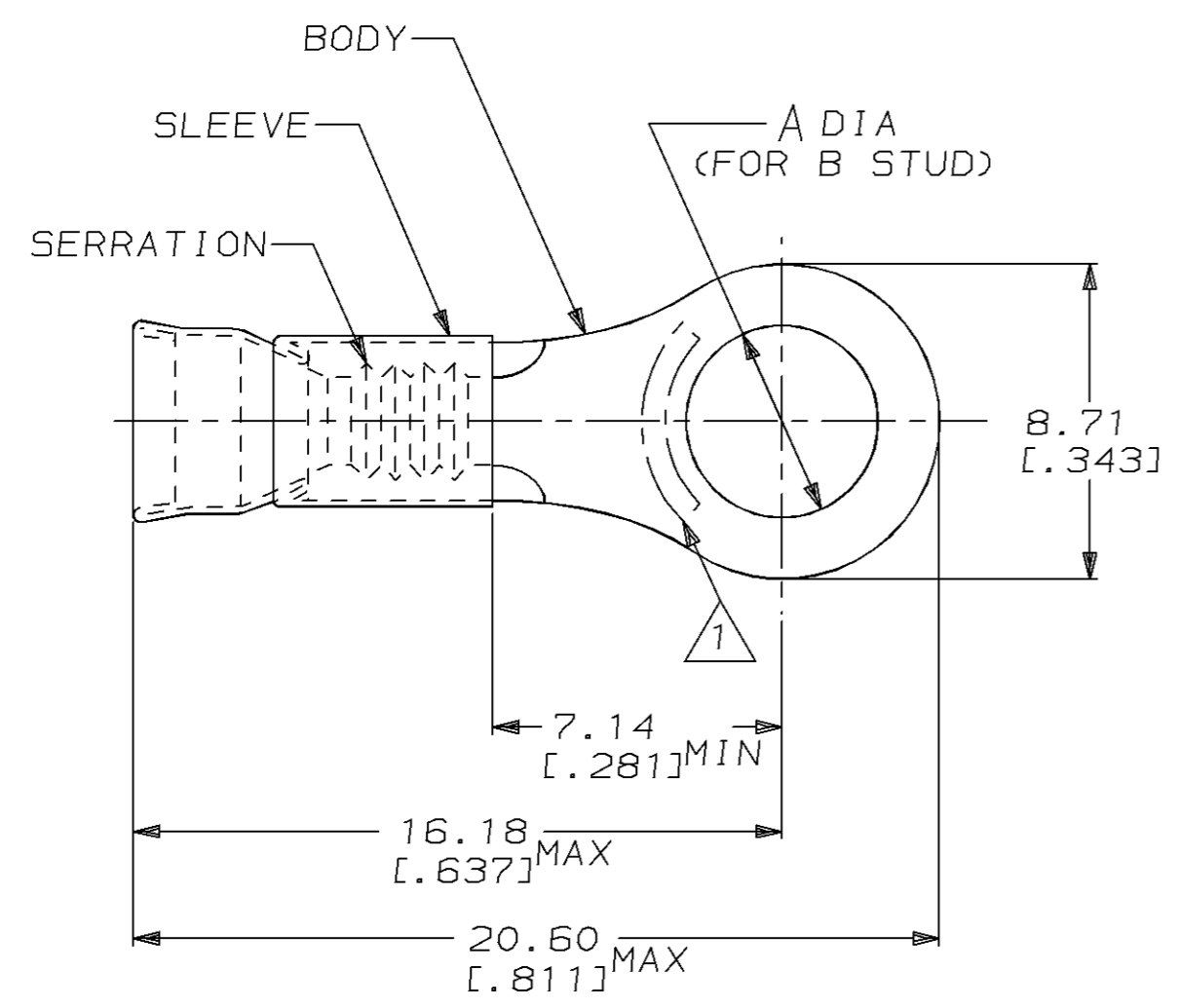

△ SEE TABLE FOR STAMPING

- 2. WIRE INSUL DIA, 3.05-4.32 [.120-.170]
- 3. TONGUE MATL THK, 0.79±0.05 [.031±.002]

AMP 16-14	4.34 ±0.08 [.171±.003]	#8	NICKEL PER ASTM B162	ORANGE	5000	ON TAPE, REEL	1-322337-2
AMP 16-14CH	5.00 ±0.08 [.197±.003]	#10	CHROMEL	GRAY	500	LOOSE PIECE	1-322337-1
AMP 16-14CH	4.34 ±0.08 [.171±.003]	#8	CHROMEL	GRAY	500	LOOSE PIECE	1-322337-0
AMP 16-14	4.34 ±0.08 [.171±.003]	#8	NICKEL PER ASTM B162	ORANGE	1000	LOOSE PIECE	322337
STAMPING	A	B	BODY MATERIAL	SLV COLOR	QTY	PACKAGE TYPE	PART NO

AMP INCORPORATED  
 CUSTOMER SERVICE SYSTEM

FOR ADDITIONAL PRODUCT INFORMATION OR COPIES OF DRAWINGS AND TECHNICAL DOCUMENTS  
 PRODUCT INFORMATION CENTER  
 1-800-522-6752

FOR APPLICATION TOOLING INFORMATION  
 TOOLING ASSISTANCE CENTER  
 1-800-722-1111

FOR ORDER ENTRY  
 1-800-526-5142

MAX RECOMMENDED OPERATING TEMPERATURE:  
 649°C [1200°F]

VOLTAGE RATING:  
 -

CIRCULAR MIL AREA:  
 1.04mm<sup>2</sup>-2.62mm<sup>2</sup> [2050-5180]

STRANDED WIRE

THIS DRAWING IS A CONTROLLED DOCUMENT FOR AMP INCORPORATED. IT IS SUBJECT TO CHANGE AND THE CONTROLLING ENGINEERING ORGANIZATION SHOULD BE CONTACTED FOR THE LATEST REVISION.

DIMENSIONS:	TOLERANCES UNLESS OTHERWISE SPECIFIED:
mm [in]	
	0 PLC ±-
	1 PLC ±-
	2 PLC ±0.20 [.008]
	3 PLC ±-
	4 PLC ±-
	ANGLES ±-

MATERIAL BODY, SEE TABLE  
 SLEEVE, NI SIL PER ASTM B122

FINISH SLV COLOR, SEE TABLE

DWN L OLMEDA	10OCT94		AMP Incorporated	
CHK M ELLIS	10OCT94		Harrisburg, PA 17105-3608	
APVD S BORTNER	10OCT94		NAME TERMINAL, RING TONGUE, STRATOTHERM, DIAMOND GRIP, WIRE SIZE, 16-14 AWG	
PRODUCT SPEC	-		SIZE A3	CAGE CODE 00779
APPLICATION SPEC	-	WEIGHT -	SCALE 6:1	SHEET 1 OF 1
CUSTOMER DRAWING		REV J		